

# B/BD/BDM Series Precision Back Pressure Regulator

## REGULATOR USE AND STARTUP

### WARNING:

Make sure that you have read and understand these directions before using, installing, or maintaining the Equilibar pressure regulator. Take steps to ensure this instruction manual reaches the operator of this regulator and stays with the regulator throughout its lifetime. Use, installation, operation, and maintenance of all pressurized products including this regulator must be performed by personnel who are properly trained and qualified through experience or specific training.

Failure to properly observe the instructions contained in this document may result in, but is not limited to:

- Serious personal injury or death
- Unconstrained release of the pressurized media
- Permanent damage to the pressure regulator and/or permanent damage to connected equipment



### BACKGROUND

The Equilibar® B/BD/BDM Series are precision back pressure regulators (BPR's). These BPR's control the fluid pressure at its inlet "I" port. The Equilibar controls the pressure by allowing excess flow to vent the system through the regulators outlet "O" port. The flow direction is from inlet to outlet. The Equilibar is pilot operated, where the pressure setpoint is determined by the setpoint pressure applied to the "Pilot" or "Reference" port on its dome. The BPR will control the pressure at its inlet port in a precise 1 to 1 relationship with the setpoint pressure applied to the pilot port. The pilot pressure may be applied with a manual pressure regulator or with an electronic pressure regulator (see Fig. 1).

The Equilibar BPR uses a flexible membrane diaphragm to both sense the pressure and to provide a direct seal against the orifices in the regulator body. The pilot pressure is applied to one side of the diaphragm. The Inlet "I" port pressure is sensed on the other side of the diaphragm. When the pilot pressure is higher than the Inlet pressure the diaphragm is pushed firmly against the orifices to form a seal and the regulator is effectively closed. When the inlet pressure builds and just equals the pilot pressure, the closing forces are removed from the diaphragm and media can begin to pass from the Inlet to the Outlet port. When sufficient media has passed through the regulator, the Inlet pressure will be reduced slightly and the diaphragm is allowed to seal against the orifices again. In normal practice equilibrium is achieved and the diaphragm modulates into a position where just enough flow is allowed out of the regulator in order to maintain a steady pressure on the Inlet port. (see Fig. 2)

**Typical Circuits:** A back pressure regulator is used to control the pressure in a system by venting any excess flow that would otherwise cause the system pressure to increase. In the example circuit shown the BPR is used to control the outlet pressure of a pump (see Fig. 3). Excess fluid is vented through the BPR back to the fluid reservoir.

Another application for the Equilibar back pressure regulator is tank blanketing. In filling a container with product, the blanketing gas or vapors in the head space must be vented to a proper disposal process to meet air quality and safety codes. Connecting the tank to the disposal system through an Equilibar back pressure regulator achieves the goal of retaining a slight pressure on the product container, yet relieving the pressure as the container fills. Equilibar B/BD/BDM series back pressure regulators are ideal for this application and can be remotely controlled by several pilot regulator options including electro-pneumatic controllers driven by your process computer. Fig. 4 represents a typical drum or tank filling installation.

Equilibar has trained engineers who can work with you to suggest a regulator design and wetted materials for your specific application. These suggestions are recommendations only and are dependent on complete and accurate information from the end user about the application.

It is the ultimate responsibility of the user to determine the compatibility of the media with the materials of construction of the back pressure regulator and with the pilot gas in use.

The diaphragm installed in the back pressure regulator is a careful balance between the pressure, temperature, media compatibility, and flow rate. Often performance in one area must be sacrificed to obtain acceptable performance in another. Many diaphragm types cannot achieve tight shutoff and must have some minimum system flow always present. If the system flow rate into the back pressure regulator is less than the minimum flow rate required by the installed diaphragm then the system pressure will fall below the target setpoint pressure.

### 2 SET-POINT OPTIONS

Fig. 1

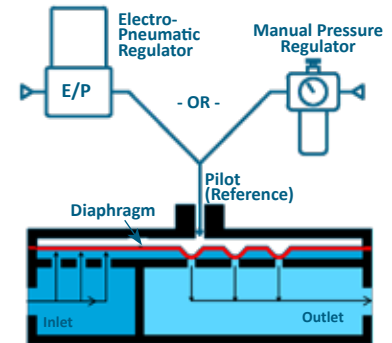

Fig. 2

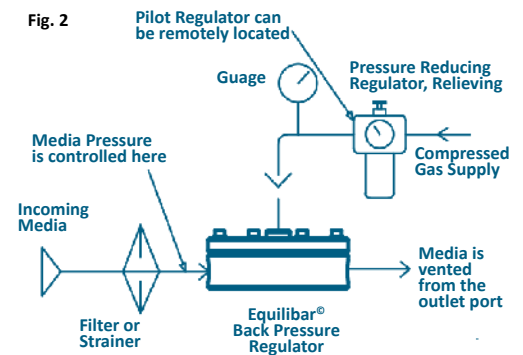

Fig. 3

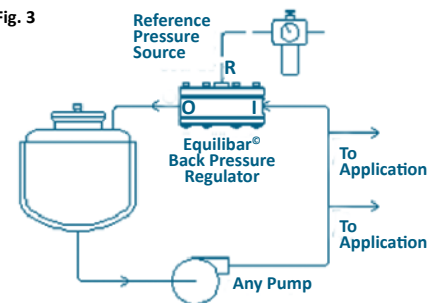
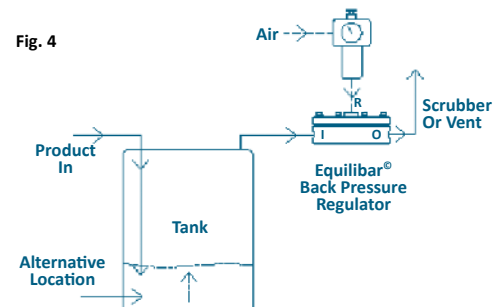

Fig. 4



# B/BD/BDM Precision Back Pressure Regulator

## PREPARING FOR INSTALLATION

- Inspect the Equilibar BPR for any damage. Consult Equilibar before proceeding if you find any damage.
- Verify that the part number on the Equilibar BPR product label matches what you had requested.
- Verify that the rating on the Equilibar BPR label for maximum allowable working pressure (MAWP) and maximum allowable working temperature (MAWT) will not be exceeded when the BPR is used.
- Call or e-mail Equilibar if you have any questions, concerns, or need a new copy of these instructions. Be sure to include the full part number and serial number of the BPR you are inquiring about. (Equilibar, 320 Rutledge Road, Fletcher, NC, 28791, USA, Phone 01-828-650-6590, [www.equilibar.com](http://www.equilibar.com), [info@equilibar.com](mailto:info@equilibar.com)).
- Take precautions to prevent injury to personnel in the event of a diaphragm failure or external leak. Sensitive fluid controls can experience internal or external leaks. See standard terms and conditions for important limitations of liability notes.
- The Equilibar BPR is not orientation sensitive and may be mounted in any plane and maintain good pressure control. Media draining or other considerations may need to be taken into account by your specific application requirements.
- Every Equilibar regulator is individually hand tested at the factory for operation and external leakage. Leak testing is typically performed at 1.5X the MAWP. Many diaphragms are manufactured with a small tab of protruding material. This is nonfunctional and is included only to allow easy inspection of the diaphragm material and thickness without the need to disassemble the regulator.
- Equilibar regulators are cleaned internally and externally at the factory using aqueous based cleaners in an ultrasonic cleaner and manual wipe down with denatured alcohol.
- A small amount of DuPont Krytox lubricant is occasionally used on the internal non-wetted O-ring.
- Inlet ports are stamped with an "I" as shown. Outlet ports are stamped with an "O".
- The inlet "I" port is connected to the point in the system where it is desirable to maintain or control the pressure. The best pressure control will be seen if the plumbing to the BPR inlet port is as short and as large as practical to minimize the amount of pressure drop in the plumbing.
- Tapered pipe thread connections will require the addition of a sealant. PTFE tape may be used if it is compatible with your process and media. Take care not to let the PTFE tape extend past the first two male threads to prevent the PTFE tape from being ingested by the regulator. Tape or other debris can prevent the BPR from closing tightly and therefore not able to maintain the back pressure at low flow rates. PTFE based pipe dope or an anaerobic "Loctite" product may also be used. Confirm the thread sealant used is compatible with your process, temperature, and media.
- Install a strainer or filter upstream of the Equilibar back pressure regulator where necessary to prevent plugging of the orifices. Recommended 100 micron/100mesh or better.
- System media will be vented out the BPR outlet "O" vent port, also called an exhaust port. Be sure that the media is vented to a safe environment, away from employees, and in accordance with applicable laws in your jurisdiction. Take care that the outlet port cannot become blocked during operation by a valve closure, snow, ice, condensate, insects, birds nesting, etc.
- Even inert gasses can cause suffocation through oxygen displacement. Take care to ensure that adequate ventilation and oxygen levels will be maintained.
- Provide adequate exhaust line capacity. Short or oversized exhaust lines are recommended.
- The Equilibar BPR is not a "Safety Accessory" as defined by the Pressure Equipment Directive 2014/68/EU. Be sure to install appropriate over pressure protection devices such as safety relief valves or rupture discs to protect the system and the BPR from exceeding the maximum allowable working pressures. These safety devices must meet applicable law, codes, regulations, and standards for your jurisdiction.
- Any bolt, screw, or connector that is threaded into a stainless steel body should have some small amount of lubricant to prevent thread galling. Threads galling together is usually permanent and causes the regulator to be scrapped. The Equilibar factory applies Swagelok® brand Silver Goop® to all bolt and screw thread connections that are not wetted by the process fluid.
- The pilot pressure is a nearly exact 1:1 relationship to the pressure being controlled. Many users find that installing a pressure gauge in the pilot port offers advantages over installing a gauge in the Inlet "I" port. The inert pilot media can be read with a less expensive gauge and the pilot pressure may be set even when there is no system media actively flowing.
- The pilot pressure should be an inert compressible gas. Incompressible media such as liquids do not make effective pilot pressures because they do not allow the BPR diaphragm to adjust. Make sure the pilot media is compatible with the media flowing through the BPR.
- Exercise caution when reducing the pilot pressure. The BPR will attempt to reduce the inlet pressure at the same rate that the pilot pressure is being reduced. This can result in extremely rapid release of media through the outlet (O) port of the regulator. Reduce the pilot pressure as slowly as practical.
- The BPR is designed to have maximum pilot pressure applied even when there is no pressurized media at the inlet (I) port. No damage will result.

# B/BD/BDM Precision Back Pressure Regulator

## ASSEMBLY INSTRUCTIONS (B/BD/BDM SERIES)

1. **[This step is applicable to polymer units only]** Insert sealing bolts (8) into the bottom plate(1) and tighten hex couplings(9) on the opposite side.
2. Insert two bolts(11) into the body (middle) plate(3) and invert the body such that the O-ring grooves are facing upward.
3. Insert the two body O-rings (7 & 5) into the body's O-ring grooves.
4. Lay the bottom plate(1) over the body plate(3), using the two large bolts(11) to align it. Make sure that the inlet port (marked with an I) is laid over the inner O-ring(7).
5. Firmly grip the body(3) and bottom plate(1) together and invert the unit.
6. **[This step is applicable to polymer units only]** Insert the countersunk socket hex bolts(10) into the two alignment holes in the center of the body(3) and bolt into the couplings(9). You can now remove the large bolts(11) used to align the body(3) with the bottom plate(1).
7. Insert the remaining body O-ring(6) into the body plate(3). B/BD/BDM units may not include an upper body O-ring.
8. Invert the reference cap(2) and insert four long bolts(11) into the reference cap.
9. Lightly lubricate the reference cap O-ring(5). This O-ring is not exposed to the process fluid and can be lubricated. B/BD/BDM units may not include a reference O-ring.
10. Inspect diaphragm for any damage. If damaged do not install. Instead, [contact Equilibar](#) for a new one. Lay the diaphragm(4) over the reference cap(2) and bolts(11), holding the O-ring(5) firmly in place.
11. Invert the reference cap(2) onto the body/bottom plates(3 & 1).
12. Gently secure the reference cap bolts using the provided washers(12), lock washers(13) and nuts(14).
13. Tighten all bolts using a torque wrench at the recommended settings referenced in **Figure A** and tightening in the torque pattern shown in **Figure B**.
14. If your rebuild kit contains a new label, be sure to apply it to the back pressure regulator as the wetted materials or operating parameters may have changed.

Note: Gap between sections should be even, but will not disappear

**Figure A: Torque Wrench Settings**

#10 or M5 bolts	55-65 in-lbf torque (6.2-7.3 N-m)
¼" or M6 bolts	65-77 in-lbf torque (7.3-8.7 N-m)
5/16" bolts	142-156 in-lbf torque (16-17.6 N-m)
3/8" bolts	200-220 in-lbf torque (22.6-24.8 N-m)
1/2" bolts	480-500 in-lbf torque (54.2-56.5 N-m)
Polymer Units	40-45 in-lbf torque (4.5-6.2 N-m)

\*Consult factory for any models, bolts not listed such as custom units. [inquiry@equilbar.com](mailto:inquiry@equilbar.com)

†Recommended Torques for Lubricated bolts

\*See Rebuilding an Equilibar Back Pressure Regulator video:  
<https://www.equilbar.com/support/assembly-rebuild-instructions/>

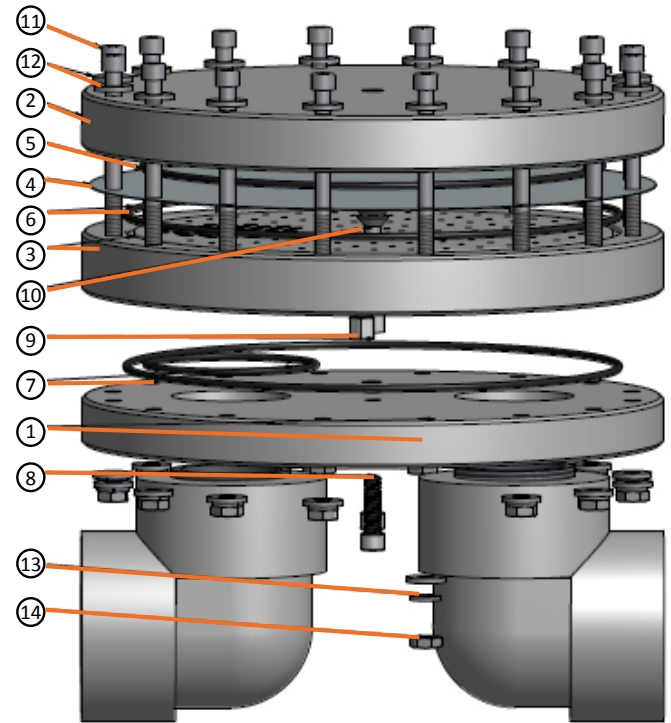

**Exploded View of Equilibar BD**

**Figure B: Sample Torque Pattern**

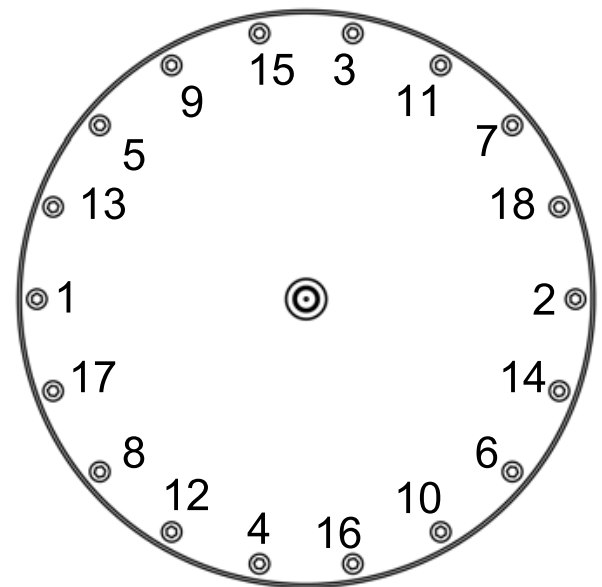

# B/BD/BDM Precision Back Pressure Regulator

## MAINTENANCE NOTES

- Maintain strainer or filter upstream of device
- Annual inspection of diaphragm integrity is recommended, especially for applications where there is strong or regular pulsing (i.e. reciprocating pump, etc.). Repair parts and kits are available for parts 3, 4 & 5.

## TROUBLESHOOTING

PROBLEM	POSSIBLE SOLUTIONS
Maximum flow is reduced	Clean out internal orifices
Will not maintain back pressure at low flow rates	<ol style="list-style-type: none"><li>1. Inspect the regulator for debris or diaphragm damage which prevents the diaphragm from sealing against the orifice in the regulator body</li><li>2. Contact Equilibar Applications Engineer to review low flow specifications</li></ol>
External leak around diaphragm	<ol style="list-style-type: none"><li>1. Check for loose bolts</li><li>2. Check for misaligned flanges, O-rings or diaphragm</li><li>3. Check for scratched sealing surface</li><li>4. Check for O-ring Damage</li></ol>
Chatter on the downstream tubing	Increase exhaust piping size Contact factory for additional assistance
Air in process exhaust	Ruptured diaphragm
Fluid out of the reference port	Ruptured diaphragm
Leaking (not from process ports)	Lubrication and/or stretching of O-rings recommended

## POLYMER UNITS AND FITTINGS

Equilibar recommends that a suitable thread sealant be used on pipe threads of plastic units and users take caution to not over torque fittings into polymer bodies. This can result in cracking or damage of the unit. Industry standard recommendation is about 1/4 turn past hand tight.

## RATED PRESSURE AND DIAPHRAGM FAILURE NOTE

Equilibar units are rated based on the customer application in most standard configurations. The pressure containing shell (body and bolts) can withstand above 4X the model maximum pressure which may be higher than the application rated pressure. Diaphragms are specified based on a safety factor of the static burst pressure of the rated pressure at room temperature (common 3x or greater safety factor). Failure of the diaphragm will not result in a sudden release of energy due to the failure of pressure boundary (body and shell).

Diaphragms may fail in the open or closed position. Proper safety precautions should be taken for either failure mode.

## INITIAL DIAPHRAGM SETTING AND PRESSURE TESTING

Equilibar recommends an initial setting of polymer and rubber diaphragms up to 1.5X of application operating pressure. This is achieved by applying pressure to the reference port of the Equilibar. This setting of the diaphragm can help the diaphragm preform at lower flow rates. For metal diaphragms Equilibar does not recommend applying a set pressure



# B/BD/BDM Series Back Pressure Regulator

## SYSTEM HAZARD ANALYSIS

Both normal operation as well as possible failure modes and foreseeable misuse must be accounted for in the design of the system which interacts with and connects to the Equilibar back pressure regulator (BPR). It is the responsibility of the end user to account for these hazards. **Please read all of the following safety and hazard precautions before installing or operating any equipment.**

- a. The BPR is not certified as or marketed as a pressure vessel safety relief valve. The BPR is a precision control valve. Guarding against overpressure must be achieved with devices designed and marketed as such.
- b. Sensitive diaphragms and external seals can leak. It is the responsibility of the end user to use this product in a way that prevents injury to personnel should leakage occur. See Standard Terms and Conditions for important Limitation of Liability notes.
- c. If the internal diaphragm ruptures or leaks, the gas or fluid on the pilot port can be introduced into the process fluid. Make sure that the fluids are compatible and not hazardous when mixed.
- d. If the internal diaphragm ruptures or leaks, process fluid can enter the pilot port plumbing.
  - i. Make sure that the process fluids and the pilot are compatible and not hazardous when mixed. Most auxiliary pressure regulators used to provide pilot pressure to the BPR are of the self-relieving design. Guard against the process fluid relieving out the pilot regulator if the BPR diaphragm fails. One method to accomplish this is to set the pilot pressure into a static volume chamber that is sealed with an ON/OFF valve after the pressure is set to the desired value. Another method is to feed the pilot pressure from the pilot regulator through a check valve to the BPR. In order to reduce the pilot pressure a bleed from the pilot port to a safe location must be employed. In many cases this bleed can be made to the output of the BPR.
  - ii. If an electronic pressure regulator is used then special consideration must be made. In addition to reviewing the prospect of having the process media coming in contact with and venting out of the electronic pressure regulator, the possibility of ignition of the media by the electronic pressure regulator must be examined. It is the users responsibility to determine if a hazardous area classification exist and to make sure that the electronic pressure regulator employed meets or exceeds the requirements of intrinsic safety for that area.
- e. If the internal diaphragm ruptures or leaks the result is often that the BPR will fail into a closed position. This results in a blocked pipe with no path for the fluid to escape through the BPR. Over pressurization of the upstream can occur. Steps must be taken to insure that the upstream piping is made sufficiently strong to withstand this or is guarded by an overpressure relief device.
- f. Make sure the process pressure to be controlled is connected to the BPR "I" Inlet port. Process fluid flow is from "I" Inlet to the "O" Outlet. If the BPR is connected in reverse it will still operate but it will give poor control and can result in excess pressures.
- g. Observe the maximum temperature and pressure ratings on the BPR label. Take steps to insure these values cannot be exceeded. Where necessary to protect equipment, a suitable type of safety overpressure relief valve must be connected in parallel to the BPR. The overpressure relief valve must be rated to prevent the pressure or temperature from exceeding the BPR maximums as listed on the BPR label.
- h. In some installations a rupture disc may be substituted for the safety relief valve.
- i. If the discharge piping on the BPR "O" Outlet port becomes blocked, the BPR will open and fill the discharge piping to the same pressure as the maximum pressure in the system. The discharge piping must be rated to contain this pressure or have a safety relief valve to limit this pressure at or below the safe pressure of the discharge piping.
- j. Do not use the BPR as a structural member. All piping and plumbing connections to the BPR should be adequately supported. The BPR series is available with a mounting bracket to facilitate the installation.
- k. Enriched oxygen media (>21%) should not be used in the BPR unless Equilibar has specifically worked with you to provide a product rated and labeled for enriched oxygen. Standard products are not oxygen cleaned. Particle impact, adiabatic compression, and diaphragm motion can all cause ignition in an enriched oxygen media. This kindling chain can cause the entire BPR to oxidize extremely rapidly resulting in high temperatures, discharge of flames and molten metal, and unrestrained escape of process fluid.
- l. The metal cap and body of the BPR are excellent conductors of heat.
  - i. Assume the external temperature of the BPR will rise or fall to match the temperature of the process media flowing through it. In addition to thermal hazards posed to humans by directly touching the BPR exterior, it is the duty of the end user to verify that the temperatures of the process media do not exceed the ignition temperatures of any combustible gases or dust (or mixture) that may be present local to the BPR.
  - ii. Assume the internal temperature of the BPR will rise or fall to match the temperature of the ambient environment. Ensure that the process media flowing through the BPR cannot be damaged or ignited by the maximum and minimum ambient environment temperatures. Low ambient temperatures can cause the media within the regulator to freeze. Expansion cooling in certain gasses can also cause freezing. Freezing can block the BPR and cause excess pressures to build on the "I", Inlet, port. Expansion of water due to freezing can damage the regulator. Ice formation from freezing can perforate metallic foil diaphragms.
- m. The BPR has been carefully designed by skilled engineers to provide proper safety ratios and adequate pressure regulation. Do not attempt to modify the BPR in any way, including adding or enlarging orifices or ports or replacing machine screws (bolts). Only replace the internal O-rings or diaphragms with Equilibar factory provided repair parts.
- n. Never perform maintenance or inspections on a system when pressurized fluids are present. De-pressurize the system before performing this work. De-pressurize inlet pressure before reference otherwise a quick drop in reference pressure can lead to a violent exhaust of the upstream pressure through the regulator.

## PATENT INFORMATION

This regulator is subject to one or more of these patents: US6,886,591, US7,080,660, US7,673,650, US8,215,336, DE60322443D1, GB1639282, FR1639282, CH1639282